

V/UHF COMMUNICATIONS JAMMING SYSTEM

- ◆ Frequency Range 20 – 3000 MHz
- ◆ 40 MHz or 200 MHz Instantaneous Bandwidth
- ◆ Application-specific Power Amplifiers and Antennas
- ◆ Standalone, Slaved or Remote Control Operation
- ◆ Fixed, Mobile & Semi-Mobile Applications



Key Features

- Configurable for full standalone operation or as part of a scalable Integrated Tactical EW System with command and control and direction finding capabilities
- Fast scanning wide band receiver technology for detection of target activity
- Full frequency coverage 20 – 3000 MHz
- 40 MHz instantaneous bandwidth (single channel receiver) or 200 MHz instantaneous bandwidth (5 channel receiver)
- Advanced wide band surveillance for local and remote updating of ECM data and network analysis
- Application-specific power amplifiers and antennas
- Multiple Electronic Attack modes and countermeasures against modern spread spectrum communications
- Priority based responsive jamming with configurable attack patterns using advanced RF jamming signal generator
- Predictive hopper follower tracking mode to follow-jam up to 512 hops/sec
- Guard channel function stops jamming on detection of activity in guard channel
- Blocked frequencies for friendly and protected bands
- Narrow band receiver for demodulation and recording of audio for analysis and manipulation
- Counter Modulation Generator (CMG) for manipulating audio for counter transmissions
- On-board ESM functions including demodulation and Advanced Signal Detection capabilities
- I2MGeo Map functionality for constructing and analyzing enemy radio networks and performing RF propagation predictions
- Optional data decoding capabilities
- Advanced BIT (Built in Test) capability verifies performance, quickly identifies faulty modules and reduces mean down time
- Windows® based displays provide user friendly interface

Applications

The Grintek Ewation V/UHF Communications Jammer is the system of choice when a proven, state of the art communications jamming capability against modern V/UHF spread spectrum communications is required.

Designed to be self-contained, with application-specific power amplifiers and antennas, the system may be installed at a fixed location for static use, or inside a transportable shelter for use in the tactical arena.



Field deployed V/UHF Communications Jamming System

System Overview

The GRJ8000 family of V/UHF ESM/ECM Communication Surveillance and Electronic Attack Sub-Systems provides the system with a fast scanning, signal searching capability and multi-waveform electronic countermeasures in the 20-3000 MHz band. A variety of power amplifiers and antennas can be interfaced for general or customer-specific applications.

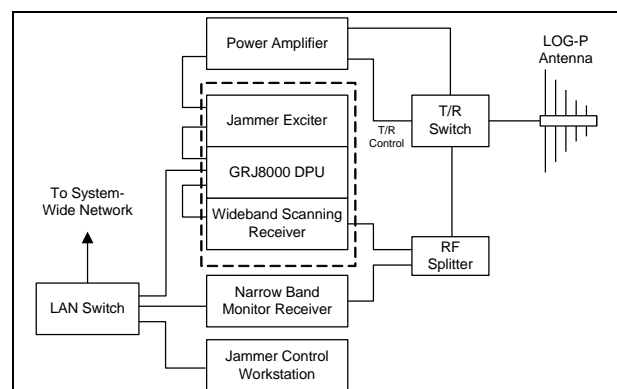

High Level System Block Diagram

A Jammer Control Workstation is used as the operator interface for tasking and controlling the GRJ8000 V/UHF ESM/ECM Communication

Surveillance and Electronic Attack Sub-System and the narrow band monitoring receiver.

Modes of Operation

The system may be deployed in an autonomous Standalone mode of operation or as part of an Integrated Tactical EW System where it is subordinate to a Tactical Operations Control Centre (TOCC) for Slaved or Remote operation.

In Standalone mode the system uses its on-board ESM functions to detect and identify target signals.

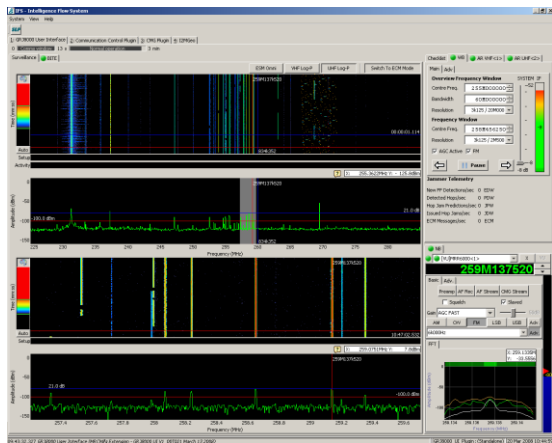

Typical spectral display for ESM functions with narrowband monitoring

In the Slaved mode of operation, jamming tasks are received from the TOCC for execution. The operator may add jamming tasks provided that they are authorized by the TOCC. The jamming system operator performs the jamming and reports back to the TOCC.

During Remote operation, the jamming system is fully operated by the TOCC. This includes rotating jamming antennas, setting up jamming parameters as well as starting and stopping jamming.

Jamming (EA) Modes

All the operational modes are accessible via the task focused User Interface that allows easy and intuitive use for manual and automated tasking. Manual tasks are simplified by using high quality graphics to take advantage of the versatile and feature-rich wide band receiver and its associated services. Some of the typical user interfaces are shown in this document. Amongst others, jamming modes include:

➤ Responsive Fixed Frequency Jamming

The system automatically jams signals on a priority basis as they are detected above a selected energy threshold for a defined channel or band. At intervals, the jamming is momentarily interrupted (look-through) to check for continued signal activity. Jamming jumps to higher priority targets upon detection of activity or ceases when the signal is no longer above the set threshold. Jamming can also be stopped when activity is detected in guard channels.

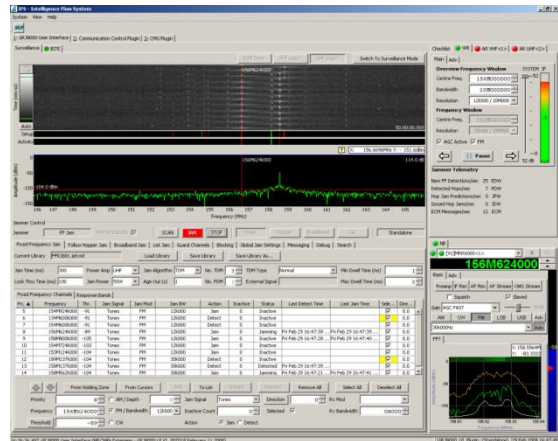

Typical user interface for monitoring and processing fixed frequency lists with associated jamming priority

➤ Hopper Follower Jamming

The GRJ8000 is set to search for activity with filter parameters pre-set for the target hopper. When signals matching these parameters are detected, advanced algorithms track the signals, predict the dwell intervals and coordinate the look-through interruptions. Each pulse of the hopper is jammed individually. Tracking and jamming status is displayed on the user interface.

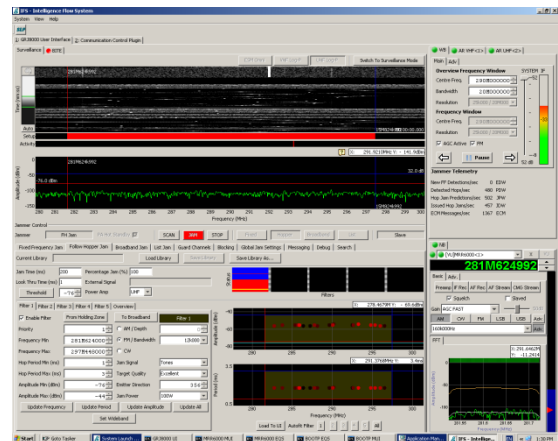

Typical user interface for Frequency Hopper signal tracking and jamming

➤ Broadband/Barrage Jamming

The wide band receiver can be used to characterize frequency hopping or spread spectrum signals. The parameters are used to define a barrage signal that matches the wideband signal. This is generated by the exciter. Multi block implementation is allowed to exclude guard and friendly channels.

➤ List Jamming

List Jamming steps through a pre-defined list of frequencies and dwell times.

➤ Jamming Attack Pattern

Fast random multiple TDM signal generation may be combined with FDM signal generation to attack multiple targets on a priority basis.

Counter Modulation Generator

The Counter Modulation Generator provides the system with a powerful tool to create and manage audio tracks from a variety of available audio inputs. Once created, these tracks may be used for modulating jamming signals for counter transmissions.

I2MGeo Map Viewer

The I2MGeo Map Viewer allows the operator to construct a model of and analyze enemy radio networks. RF propagation predictions can be performed for optimal jamming parameter selection.

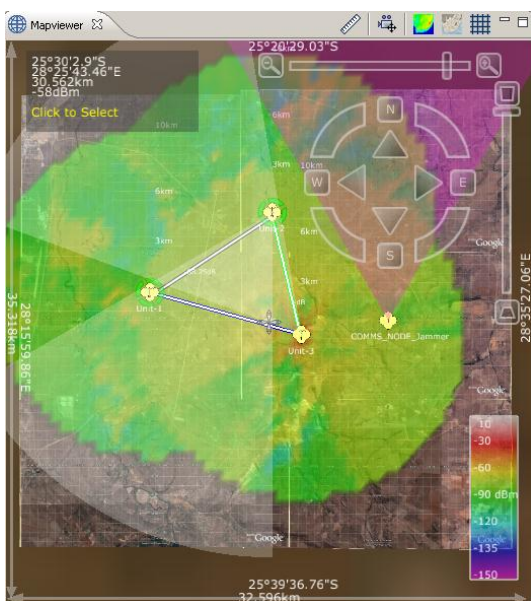

Typical I2MGeo Map Viewer

Integrated Tactical EW System

The V/UHF Communications Jamming System may be integrated into a company level Tactical EW System typically consisting of the following:

- Tactical Operations Control Centre (TOCC)
- V/UHF Communications Jamming Systems
- V/UHF Direction Finding (DF) Systems

The primary purpose of the Tactical EW System is to support the battlefield commander in his tactical decision-making through the collection of enemy communications information and the disruption of enemy command and control capabilities.

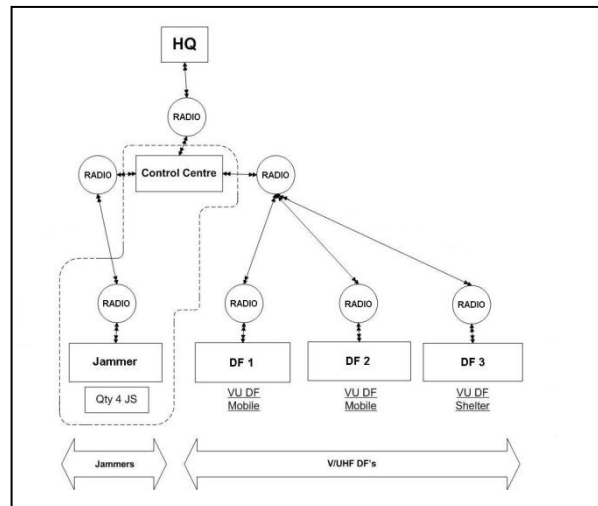

Integrated Tactical EW System

The secondary purpose is to supply intercepted information to the strategic domain for processing, validation, analysis and direction.

The system architecture is scalable and several Tactical Operations Control Centers, V/UHF Communications Jamming Systems, V/UHF Direction Finding Systems and a System Control Centre may be integrated to meet operational requirements up to battalion level.

➤ Tactical Operations Control Centre

The Tactical Operations Control Centre is responsible for tasking and directing the ESM and ECM (EA) systems.

Key features of the Tactical Operations Control Centre include:

- Spectrum surveillance (20-3000 MHz)
- Mission and task setup and distribution
- Accumulation of information collected by the V/UHF DF systems
- DF requests and best point calculation
- Recording of jamming results for post mission analysis
- IF and AF data decoding
- Control and tasking of jamming systems
- Full remote control of jamming systems
- Geographic display of battlefield layout, DF lines-of-bearing, best points, jamming antennae sectors and jamming activity



Field deployed Tactical Operations Control Centre

➤ V/UHF DF System

The V/UHF Direction Finding System is dedicated to the ESM function of the Integrated Tactical EW System.

Key features of the V/UHF Direction Finding System include:

- Automatic DF of target signals and return of line-of-bearing (LOB) when tasked by the TOCC
- Advanced Signal Detection for identifying and doing direction finding on frequency agile signals
- Streaming and recording of digital audio and IF data
- AF and IF data decoding and classification
- Linking of audio and IF recordings, LOBs, best points, decoded data and other detections to an intercept for database storage
- Geographic display of LOBs and best points



Field deployed Tactical V/UHF Direction Finding System

Contact us at marketing@ewation.co.za or visit our homepage: <http://www.gew.co.za>

Not binding for delivery
Subject to change without notice